

# *KinetSync-SR* Ô

**Brush -Type Synchronous  
Motor Controller**

## **Instruction Manual**

Program Revision:



**Factory Pre-Programmed Password:**  
**[ FWD-BACK-INC-DEC ]**

---

***Kinetics Industries Inc.***

*140 Stokes Avenue  
Trenton, N.J. 08638*

*phone: 609-883-9700*

*fax: 609-883-0025*

[info@kinetics-industries.com](mailto:info@kinetics-industries.com)

# ***KinetSync-SR™*** by *Kinetics Industries Inc.*

**140 Stokes Avenue  
Trenton, New Jersey 08638**

## **Table of Contents**

<b>Table of Contents</b>	<b>page 1</b>
<b><i>KinetSync-SR</i> Functions and Description</b>	<b>page 2</b>
<b><i>Synchapp-SR</i> Brush-Type Synchronous Motor Exciter/Application System</b>	<b>page 3</b>
<b><i>Synchapp-SR</i> and <i>KinetSync-SR</i> Connections</b>	<b>page 3</b>
<b>Required Motor Starter Control Inputs</b>	<b>page 3</b>
<b>Output Connections to the Motor Starter</b>	<b>page 3</b>
<b>Internal Connections between SVR and <i>KinetSync-SR</i></b>	<b>page 4</b>
<b><i>KinetSync-SR</i> Control Connection Layout Drawing</b>	<b>page 4</b>
<b>Installation</b>	
<b>Receipt Inspection</b>	<b>page 5</b>
<b>Mounting the <i>KinetSync-SR</i></b>	<b>page 5</b>
<b><i>KinetSync-SR</i> Dimensions and Panel Cutout</b>	<b>page 6</b>
<b>Electrical Installation</b>	<b>page 7</b>
<b>Typical <i>Synchapp-SR</i> &amp; <i>KinetSync-SR</i> Schematic Drawings</b>	
<b>Sheet 1 – <i>Synchapp-SR</i> SVR Regulated Exciter</b>	<b>page 8</b>
<b>Sheet 2 – <i>KinetSync-SR</i> Controller</b>	<b>page 9</b>
<b><i>KinetSync-SR</i> Ratings and Specifications</b>	<b>page 10</b>
<b>Sequence of Operation of <i>Synchapp-SR</i> with <i>KinetSync-SR</i> controller</b>	<b>page 11</b>
<b><i>KinetSync-SR</i> LCD Display Screen and Messages</b>	<b>page 12</b>
<b>Figure - LCD Display Annunciation Locations</b>	<b>page 12</b>
<b>Normal Operating Status Messages</b>	<b>page 12</b>
<b>Fault Messages</b>	<b>page 12</b>
<b>Digital Input Codes</b>	<b>page 13</b>
<b><i>KinetSync-SR</i> Touch Pad and LCD Display</b>	
<b>Touch Pad Functional Description</b>	<b>page 14</b>
<b>Touch Pad Layout Pictorial</b>	<b>page 14</b>
<b>Fault Acknowledge and Reset Function</b>	<b>page 15</b>
<b><i>KinetSync-SR</i> Functional Time Line</b>	<b>page 16</b>
<b>Viewing <i>KinetSync-SR</i> Timer and Meter Settings</b>	<b>page 17</b>
<b>Adjusting <i>KinetSync-SR</i> Timers and Meter Settings</b>	<b>page 17</b>
<b><i>KinetSync-SR</i> Timer Descriptions</b>	<b>page 18</b>
<b>Adjusting Metering Display Calibration</b>	<b>page 20</b>
<b>Scaling Factors and Offsets</b>	<b>page 21</b>
<b>Power Factor Scaling Factors</b>	<b>page 22</b>
<b><i>KinetSync-SR</i> Metering Parameters</b>	<b>page 23</b>
<b>KS_Parm Program Description</b>	<b>page 23</b>
<b>Additional Functions of the KS_Parm Program</b>	<b>page 23</b>
<b>Trouble shooting Guide for <i>KinetSync-SR</i></b>	<b>page 24</b>
<b>Additional <i>KinetSync-SR</i> Troubleshooting Notes</b>	<b>page 27</b>
<b>How to Get Assistance</b>	<b>page 30</b>

# ***KinetSync-SR™ by Kinetics Industries Inc.***

140 Stokes Avenue

Trenton, New Jersey 08638

## **The KinetSync-SR<sup>Ô</sup> Functions and Description**

- It monitors the starting and running condition of a brush-type synchronous motor.
- It monitors the presence and frequency of the discharge circuit current of the synchronous motor field during motor starts and uses this signal to apply the field at the proper slip frequency and optimum rotor phase angle while protecting the motor against abnormal starting conditions.
- It provides control of the static field exciter of the motor to apply DC power to the motor field at the proper time during motor starts.
- It provides annunciation of the motor starting and running sequence, motor power factor, and the exciter DC volts and amperes.
- It provides protection against various motor excitation malfunctions while starting or running the motor and annunciates the problems which include:
  - DC present on the field at the incorrect time
  - Discharge current not present during start
  - Failure to move out of locked rotor position on start
  - DC not present when required
  - Failure to achieve synchronization – Incomplete Sequence
  - Loss of field after achieving synchronization
  - Low power factor or impending pull-out of synchronous running operation
- The *KinetSync-SR* provides a power factor vernier signal to its companion Kinetics SVR-type regulated static exciter rectifier to maintain a preset motor power factor under varying loads and conditions.
- With an operational fault, the *KinetSync-SR* shuts down the motor (via the FAL relay), annunciates the fault (both audibly and visually), and then provides, via its Touch Pad, the ability to at first acknowledge the fault, and then reset the control.
- It maintains a record of the last five faults, including the fault identity and the date and time of fault. This fault record is accessible via the RS232 serial port using Kinetics' KS\_Parm Windows PC software.
- The *KinetSync-SR* provides for access to its internal sequencing timer settings and meter parameters by using either the Touch Pad on the face of the *KinetSync-SR* or KS\_Parm software. Modifying the settings using the faceplate Touch Pad requires the user to enter the Touch Pad Password. *Note: The touch-pad is locked out while the motor is running; therefore, no modifications can be made using the Touch-Pad during motor operation.* Modifying these same settings on-line, using the Kinetics' KS\_Parm software, can be done whether the motor is running or not.
- The *KinetSync-SR* provides remote annunciation of motor achieving synchronization via the *KinetSync-SR* FAX relay dry contact.

# ***KinetSync-SR™ by Kinetics Industries Inc.***

**140 Stokes Avenue  
Trenton, New Jersey 08638**

## ***Synchapp-SR Brush-Type Synchronous Motor Exciter/Application System***

The *KinetSync-SR™* controller, when operating in conjunction with the Kinetics Industries SVR-type SCR regulated rectifier, provides a complete, integrated, static excitation system. The Kinetics SVR regulator accepts and provides the necessary I/O signals for the integrated operation and control of the brush type synchronous motor. This combination constitutes the *Synchapp-SR* excitation system.

The *KinetSync-SR* can function adequately with other regulator/exciter but care must be exercised that the signal parameters are compatible and properly interfaced.

### ***Synchapp-SR and KinetSync-SR Connections***

The *Synchapp-SR* system power connections are separate from the control, made directly to power components. These connections include the 3-phase power to the Input Circuit Breaker and the Motor Field wires directly on the SVR Rectifier Output.

All internal control connections between the *KinetSync-SR* and the SVR regulator are factory pre-wired. All control connections are made using the SVR I/O terminal strip and the I and O terminals of the *KinetSync-SR* except for the connection of the Hall Effect current and voltage transducers from the regulator to the *KinetSync-SR*. Special cables, with custom plugs, are provided to connect the Hall Effect Voltage and Current Transducers from the Rectifier Power Board to headers on the rear panel of the *KinetSync-SR*.

The *Synchapp-SR* system is provided with an Input/Output terminal strip where all Customer Control Connections are made.

#### **Required Motor Starter Customer Control Inputs:**

- One N.O. dry contact which closes upon motor start – (52M)
- One N.O. dry contact which closes upon “motor full volts” (if used)
- PT signal from A-B phase PT
- CT signal from C phase CT

#### **Output Connections to the Motor / Starter:**

- Motor Field Excitation DC power from the SVR rectifier
- FAL N.O. contact, (energized when OK), for use in motor contactor stop circuit. If circuit breakers with shunt trips for stop are used for motor starting, the optional “open when OK” FAL N.C. contact can be used.
- 56K Repetitive Motor Restart Lockout contact to series with Start circuit
- FAX relay contacts for remote “Motor Synchronized” annunciation

# KinetSync-SR™ by Kinetics Industries Inc.

140 Stokes Avenue  
Trenton, New Jersey 08638

## Internal Connections between SVR regulator and KinetSync-SR include:

- 120VAC control power
- Thermal or overload contacts
- PT signal from phase A-B
- Aux CT signals from auxiliary CTs
- FS relay contacts to control SVR rectifier “ON” function
- P.F. vernier signal to SVR rectifier for P.F. regulation of motor
- Freewheeling and Discharge SCR Trigger control
- Field Voltage and Current signals from Hall Effect Transducers
- Discharge Current signal from Hall Effect Transducer
- 56K relay contacts for “Repetitive Restart” Motor Lockout function
- Digital outputs to (optional) Programmable Controller

### KinetSync-SR Control Connections Layout

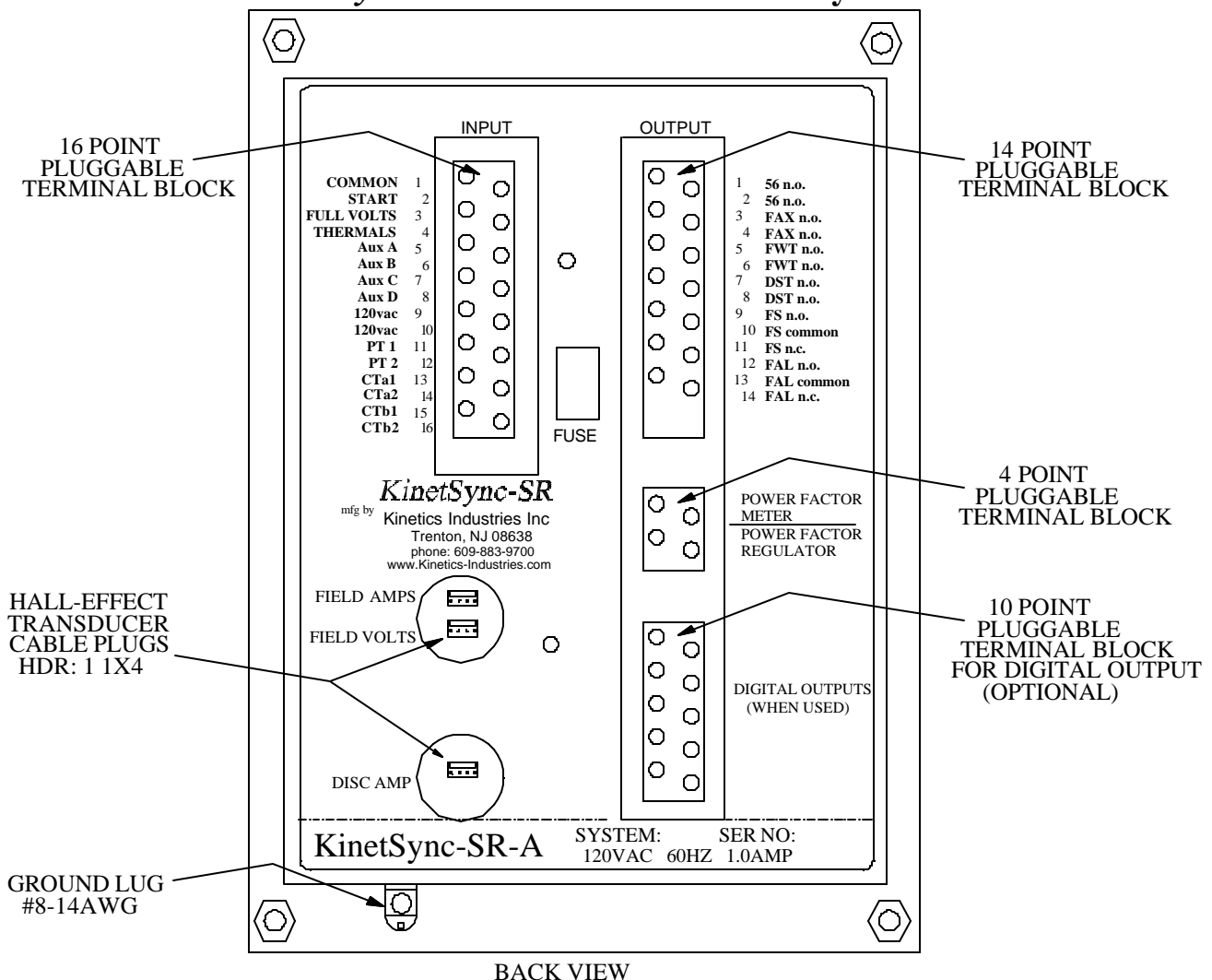

# ***KinetSync-SR™ by Kinetics Industries Inc.***

**140 Stokes Avenue  
Trenton, New Jersey 08638**

## **Installation**

The Kinetics Industries *KinetSync-SR* Controller is available as part of an integrated Kinetics Synchronous Motor Field Application System or as separate panel-mounted sequencing control and protection device for use with a third party Field Exciter/Regulator.

When part of a Kinetics Synchronous Motor Field Application System, the *KinetSync-SR* can be supplied either as a pre-mounted component on a stand-alone Kinetics system enclosure or as a separate panel-mounted piece included along with a field regulator panel for mounting in existing switchgear cabinets.

## **Receipt Inspection**

When supplied as a separate, panel-mounted, component, the *KinetSync-SR* box should be unpacked, inventoried, and checked for any apparent shipping damage as soon as possible after receipt. *All shipping damage found should be documented and reported to the shipping carrier and Kinetics Industries.*

Your *KinetSync-SR* package should include (at a minimum) a *KinetSync-SR* Controller, a package of pluggable (input/output) terminal strip blocks, and a copy of this Instruction Manual.

## **Mounting the *KinetSync-SR***

This section provides the information for installing the *KinetSync-SR* into a metal cabinet panel (or door).

Before mounting the *KinetSync-SR* you must prepare the cutout location. Prepare the mounting hole for the controller case in the existing door or panel to the dimensions shown on the *KinetSync-SR* Dimension and Panel Cutout Drawing. (see page 6)

Prior to installing the *KinetSync-SR* into the panel cutout, remove the mounting hardware from the four bolts located on the back of the *KinetSync-SR* faceplate at the four corners. Save this hardware to secure the controller to the panel after it is in place.

Insert the *KinetSync-SR* case into the panel cutout from the front, making sure that the controller LCD display screen faces out. *(It may be necessary to tilt the case top forward slightly to insert the bottom ground lug into the prepared cutout first before sliding the remainder of the controller case completely into place).*

Re-install the mounting hardware onto the four mounting bolts from the rear of the panel and tighten to secure the Controller in place. The *KinetSync-SR* is now installed and ready for wiring.

# KinetSync-SR™ by Kinetics Industries Inc.

140 Stokes Avenue  
Trenton, New Jersey 08638

## KinetSync-SR Dimensions and Panel Cutout

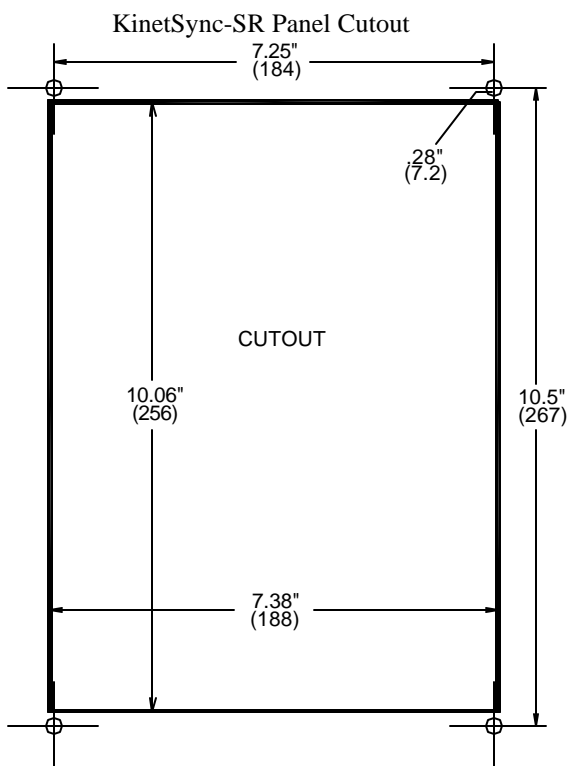
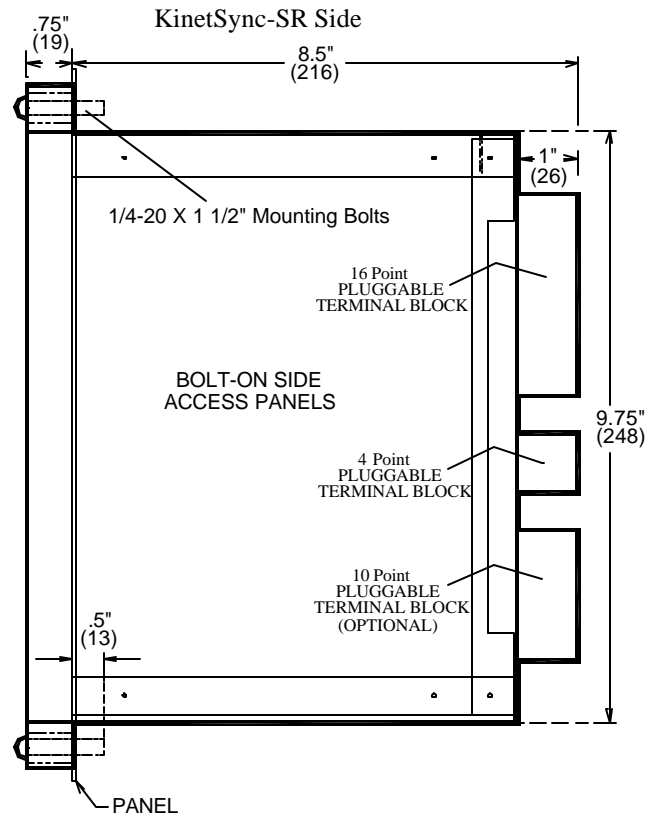
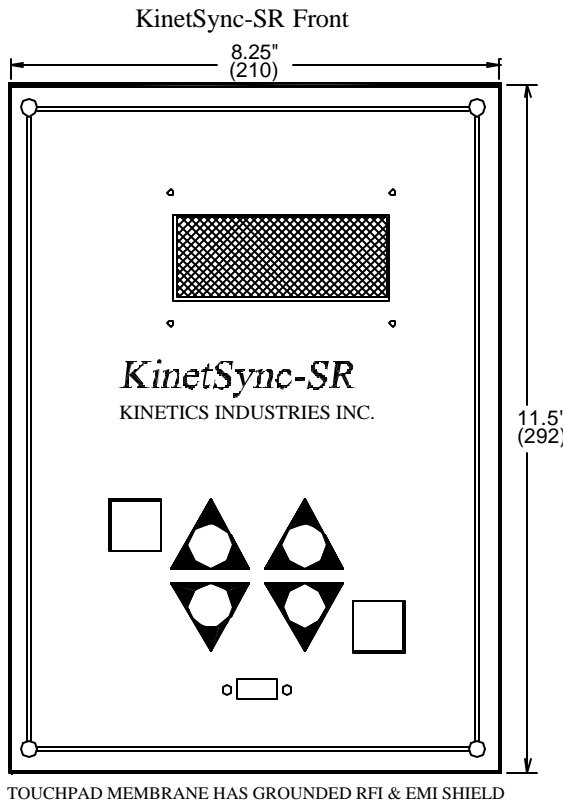

# ***KinetSync-SR™*** by *Kinetics Industries Inc.*

140 Stokes Avenue  
Trenton, New Jersey 08638

## **Electrical Installation**

### **Grounding**

The *KinetSync-SR* must be properly grounded to system ground via the ground lug located on the bottom of the Controller case.

### **Input Control Connections**

- Start – Motor “ON” Contact Input (M “aux” contact)
- Full Volts – Reduced Voltage Start: “Full Volts” Contact Input
- Thermals – Thermal Protection Circuit Input (Jumper Input when Not Used)
- 120vac – Control Power Input

### **Motor Starter PT and CT Connections**

The *KinetSync-SR* is designed to work from a 120vac Potential Transformer (PT) secondary voltage and a 5amp Current Transformer (CT) secondary signal feeding a Kinetics PT/CT Input Module that, in turn, connects to the Controller PT and CT inputs. The Motor PT and CT connections must be made in the correct motor phase configuration for the proper operation of the *KinetSync-SR* Controller.

The *KinetSync-SR* requires that the PT and CT signals be connected in quadrature.

Possible correct PT/CT combinations:

- CT phase C PT phase A-B
- CT phase A PT phase B-C
- CT phase B PT phase C-A

### **Field Amps, Field Volts, Discharge Amps Transducer Connections**

The Field Amps, Field Volts and Discharge Amps connections on the back of the *KinetSync-SR* are designed to operate with Kinetics-provided Hall Effect isolating transducers and cables.

### **Relay Output Connections**

- 56 – Repetitive Restart Interlock Contact – Closed = ok to start
- FWT – Kinetics SVR Free-Wheeling SCR Enable Contact
- DST – Kinetics SVR Field Discharge SCR Enable Contact
- FAX – “Motor Synchronized” Output Annunciation Contact
- FS – Exciter Field Application Contact – to “Energize Field”
- FAL – System Fault or Trip Contacts – n.o. Opens on Fault

### **Power Factor Control Connections**

- Power Factor Meter – Output to Kinetics Power Factor Meter
- Power Factor Regulator – Power Factor Regulation Signal Output (-5.0V – +5.0V analog signal from 0.2 Lagging to 0.2 Leading)

### **Digital Output Connections**

**Digital Outputs Connections  
(When Used)**



# KinetSync-SR™ by Kinetics Industries Inc.

140 Stokes Avenue  
Trenton, New Jersey 08638

## Typical Synchron-SR & KinetSync-SR Schematic Drawings

This figure is a typical schematic drawing presented for descriptive purposes only. See your exciter Operation and Maintenance Manual for your system-specific schematics.

### Sheet 1 – Synchron-SR SVR Regulated Exciter

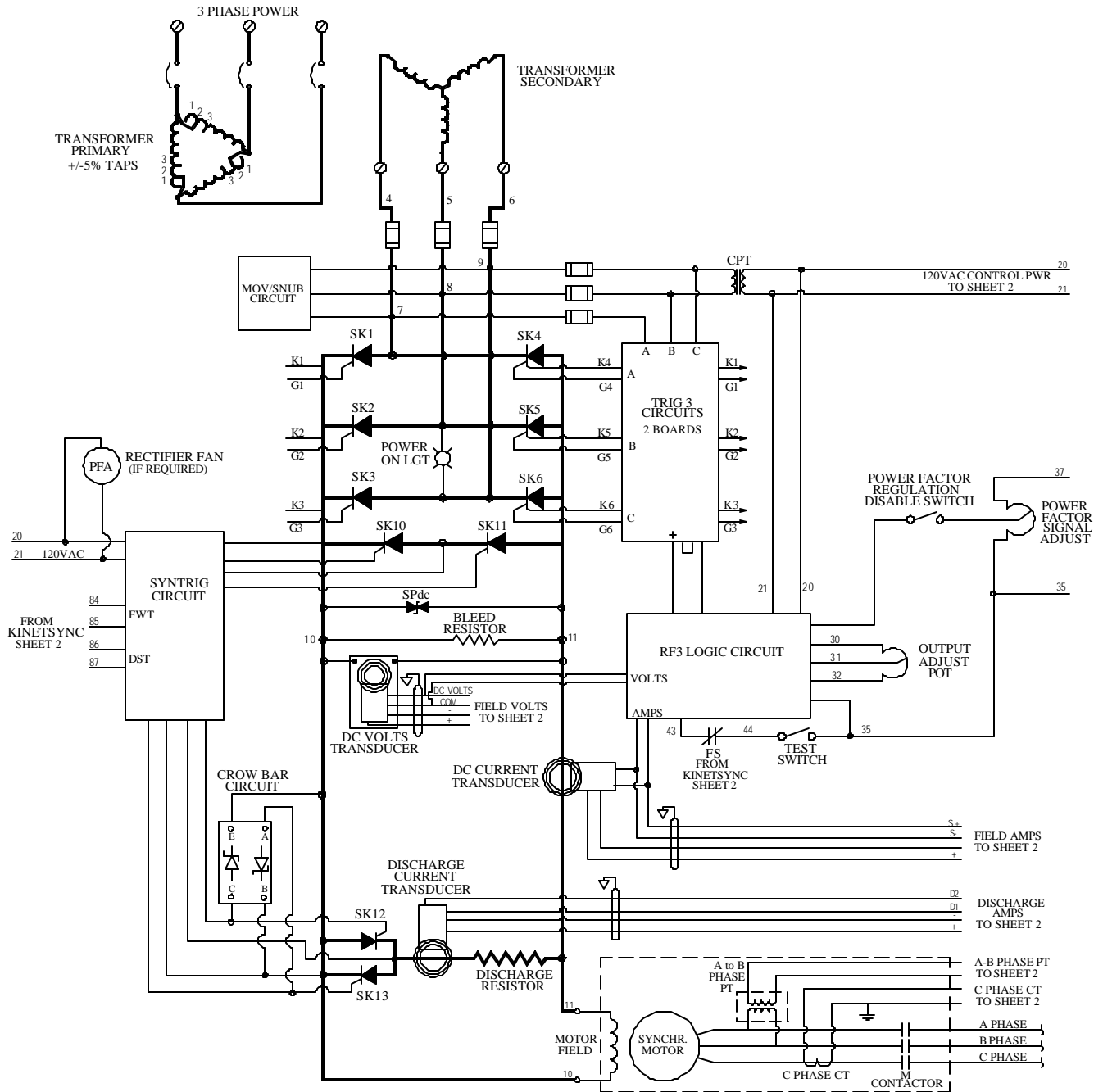

# KinetSync-SR™ by Kinetics Industries Inc.

140 Stokes Avenue  
Trenton, New Jersey 08638

## Typical Synchapp-SR & KinetSync-SR Schematic Drawings

This figure is a typical schematic drawing presented for descriptive purposes only. See your exciter Operation and Maintenance Manual for your system-specific schematics.

### Sheet 2 – KinetSync-SR Controller

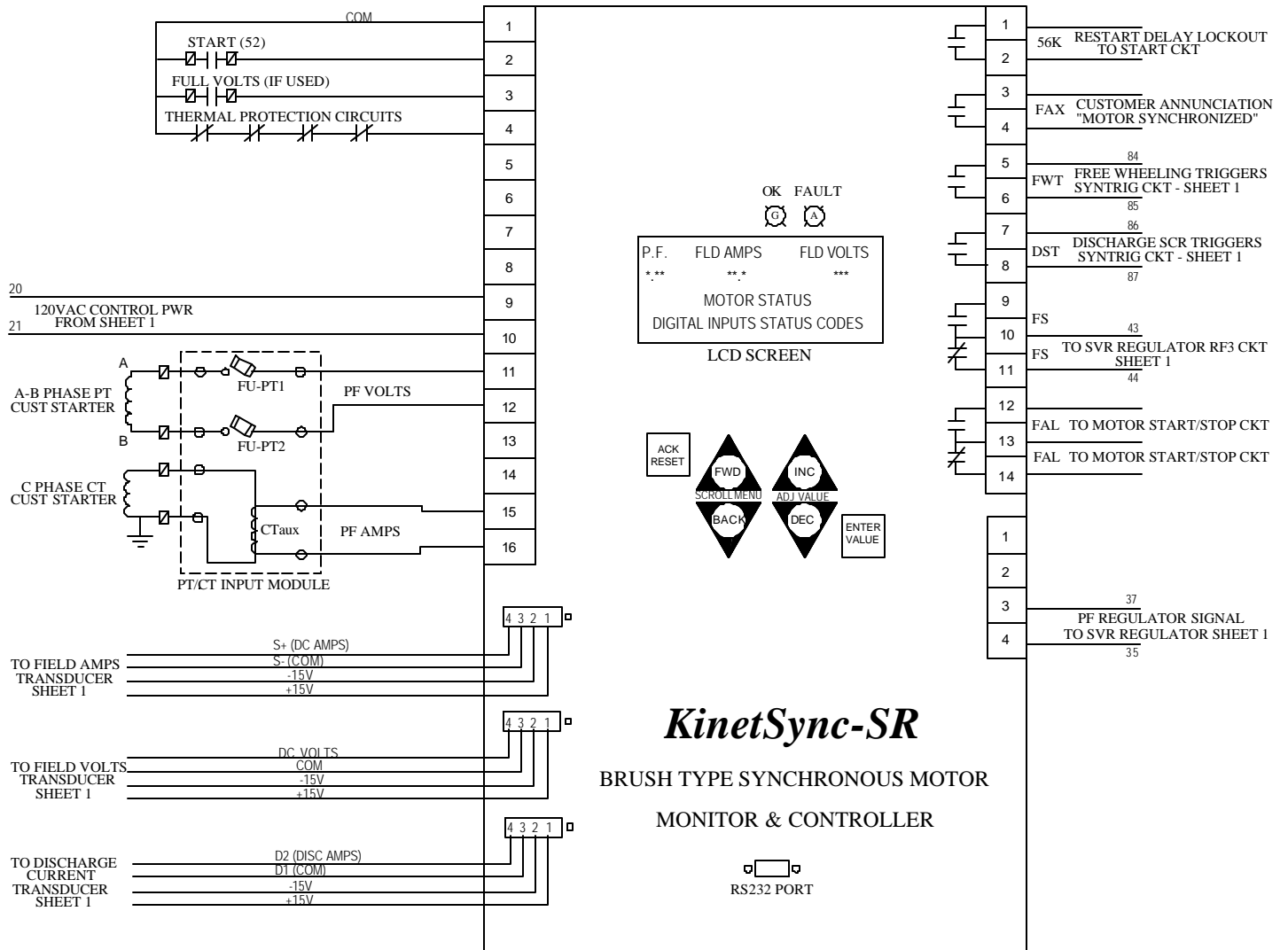

TYPICAL SIMPLIFIED MOTOR START CIRCUIT

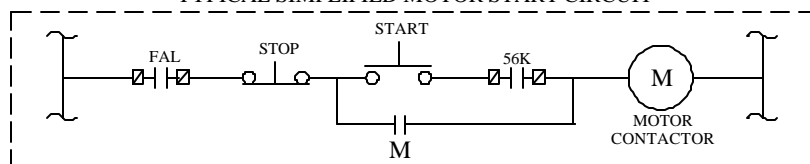

NOTE:  
☐ - CUSTOMER CONTROL CONNECTION POINT

# ***KinetSync-SR™*** by *Kinetics Industries Inc.*

140 Stokes Avenue  
Trenton, New Jersey 08638

## ***KinetSync-SR™*** Ratings and Specifications

**Power: 120VAC, 1 Phase, 60 Hertz 1.0Amp**  
**Line Fuse: 1.5Amp, 125VAC, Plug-in-type, 10KAIC @ 125VAC**

**Motor Starter Metering inputs for power factor readout and control:**

**Use PT/CT input module**

**PT: phases A-B – 120VAC to 240VAC -- .03 VA burden @ 120vac**

**CT: 5 amp secondary to PT/CT input module -- .02 VA burden 50/60 Hz**

**Power factor readout and regulator power factor control vernier signal**

**-0.2 (lag) to 1.0 to +0.2 (lead) – LCD digital display [\*.\*\*] corresponds to:**

**-2.8VDC to 0.0V to +2.8VDC – 5 Kohm load – vernier power factor signal to regulator**

**Controller Switch Inputs:**

**Dry contacts – [(collector sinking configuration) – Vce 15VDC]**

**Controller Output Contacts:**

**All relays have form C contacts rated 6A continuous at 120VAC/240VAC/24VDC**

**Relays FAL and FS have all connections brought to Output Terminal strip**

**Relays 56K, FAX and Aux Relays 3 and 4 only have type A (n.o.) contacts accessible by Output Terminal strip**

**Exciter Field Volts and Field Current Transducers:**

**Designed to operate with Hall Effect isolating transducers (2500 VAC rms isolation) either incorporated in Field Exciter/Regulator or provided for separate mounting.**

**Field Volts: Rated VDC → 4.0VDC input to *KinetSync-SR* – digital display \*\*.\***

**Field Amps: Rated ADC → 4.0VDC input to *KinetSync-SR* – digital display \*\*\***

**Discharge Amps: Rated ADC → 4.0VDC input to *KinetSync-SR***

**Environment:**

**Designed for convection-cooled enclosures**

**Ambient temperatures: -20°C to +50°C:**

**Humidity: 0-95% non-condensing**

**Specifications subject to change without notice**

# ***KinetSync-SR™*** by *Kinetics Industries Inc.*

140 Stokes Avenue  
Trenton, New Jersey 08638

## **Sequence of Operation of *Synchapp-SR* with *KinetSync-SR* Controller**

- When control power is applied, the *KinetSync-SR* checks for starting conditions. If OK, it closes the FAL contact and gives the “OK to Start” message on LCD screen.
- Starting the motor closes the start contact and the *KinetSync-SR* begins to track the starting of the motor using the current in the discharge path of the rotating field. A “Motor Synchronizing” message appears on the LCD screen while the motor goes through the start-up sequence to synchronize.
- The Controller must see Discharge Current within a preset time indicating a proper discharge path is present. If not, a "No Discharge Current" fault is indicated.
- The *KinetSync-SR* monitors the frequency of the discharge signal for a locked rotor. The frequency of the Discharge Circuit Signal must drop by 10% within a preset time indicating the rotor is turning. If not, a "Locked Rotor Fault" is indicated.
- A delay time is provided to allow the rotor to get past starting torsional effects, after which, the Discharge Current Signal is again monitored for frequency. From this frequency signal, the *KinetSync-SR* determines when the desired synchronization speed is achieved and it then applies field on the next zero crossing going positive for synchronizing at optimum rotor phase relationship.
- The rectifier Free Wheeling SCR devices are triggered on, the anti parallel Discharge Circuit SCR triggers are switched off and the FS relay activates the Exciter SCRs to apply DC to the Motor Field winding.
- The *KinetSync-SR* must see DC Field Current within a preset time (normally 3 sec); if not, it indicates a “No Field Current” fault, tripping the motor.
- The *KinetSync-SR* must also detect an acceptable Power Factor improvement to confirm motor synchronizing; otherwise, it indicates a “Low Power Factor” fault, tripping the motor.
- If Power Factor comes up to acceptable value, the *KinetSync-SR* annunciates “Motor Running” message on the LCD screen.
- Where a “Reduced Voltage” motor starter is used, the *KinetSync-SR* looks for a motor “Full Volts” dry contact to close during the Motor Start Sequence. If this contact fails to close within a pre-programmed time, the controller indicates an “Incomplete Sequence” fault and trips the motor. If a Reduced Voltage starter is NOT used, a jumper should be permanently installed between the “FULL VOLTS” input and Common (Input Terminals strip points 3 and 1).
- After Synchronization, if the Exciter Field Amps drop below a preset minimum level, a “DC Field Fault” is indicated and the motor is tripped.
- After Synchronization, if the Motor Power Factor drops below a preset lag level, a “Pullout Fault: Lo PF” fault is indicated and the motor is tripped.
- After a Motor Stop, if the Motor Restart Interlock timer (56K) has not yet timed out then the “OK to Start” function is disabled and “Restart Delay Lock” is displayed until the Motor Restart timer times out.

# ***KinetSync-SR™ by Kinetics Industries Inc.***

140 Stokes Avenue  
Trenton, New Jersey 08638

## ***KinetSync-SR LCD Display Screen and Messages***

- During normal operation, the first two lines of the LCD show Motor Power Factor, Rectifier/Exciter DC Field Amps and Rectifier/Exciter DC Field Volts.
- The third line of the LCD shows System “Status” or “Fault” Messages.
- The fourth line of the LCD displays Digital Input Status Codes indicating the “real time” ON/OFF status of selected Digital Inputs signals during operation.

PF	AMPS	VOLTS
*1.00	15.0	150
OK TO START		
p n	DA RF Fld	PFHi MFV

**Figure - LCD Display Annunciation Locations**

The \* in the PF display indicates “-“ when lag and “+” when lead

### **Normal Operating Status Messages:**

**“OK to Start”** - *KinetSync-SR* detects no faults and system is prepared for motor start.

**“Motor Synchronizing”** – motor start detected – *KinetSync-SR* system is monitoring motor starting sequence for faults while preparing to apply field.

**“Motor Running”** – Motor has come up to synchronizing speed, field has been applied, power factor and exciter field current are within operating limits and motor is operating OK.

**“Restart Delay Lock”** – Motor has stopped and 56K Repetitive Restart Motor Lockout timer has not yet timed out allowing motor to be restarted.

**“Motor Fault”** – A Motor Fault has been detected and the *KinetSync-SR* is in Fault Shutdown mode. See concurrent Fault Message.

### **Fault Messages:**

**“DC On Before Start”** - *KinetSync-SR* has detected rectifier output volts on before the system has called for it.

**“Low PF Before Start”** – Prior to receiving a Motor Start signal, the *KinetSync-SR* has detected a low (lagging) motor power factor, indicating that the motor is running.

**“No Discharge Current”** – After start, no Field Discharge Current signal has been detected, indicating a possible open Discharge Circuit.

**“Locked Rotor Fault”** - After start, the Discharge Current signal frequency has not dropped below a preset Locked-Rotor threshold level within the preset time interval.

**“Discharge Ckt Fault”** – During the motor acceleration, the *KinetSync-SR* controller is not sensing the correct field Discharge Circuit current signal “zero crossings”.

**“No Field Current”** – The *KinetSync-SR* has sent a turn-on signal to the Field Exciter and has detected no Field Current within a preset time interval.

# ***KinetSync-SR™ by Kinetics Industries Inc.***

**140 Stokes Avenue  
Trenton, New Jersey 08638**

**“Low Power Factor”** - The *KinetSync-SR* has sent a turn-on signal to the Field Exciter and has detected no improvement in Motor Power Factor to indicate that the motor has synchronized properly.

**“DC Field Fault”** – The *KinetSync-SR* has detected a loss of Exciter Field Current while the motor is running synchronized.

**“Pullout Fault: Lo PF”** – While running synchronized, the Motor Power Factor has dropped below the preset low power factor threshold that indicates improper motor operation or excitation and the possibility of a “Pull Out” of synchronization.

**“Motor Hi Temp”** – The *KinetSync-SR* has detected a high temperature fault indication from the external thermal protection circuit.

**“Incomplete Sequence”**- Motor has not completed one or more of the steps required in its start up sequence within the preset allotted time.

## **Digital Input Codes:**

**“p”** - Discharge current zero crossing pulses are being received.

**“n”** - Zero crossing pulse counter (used for diagnostic purposes to confirm pulses).

**“DA”** - Discharge Amps signal – displayed when discharge current is detected.

**“RF”** - High Rotor Frequency signal – displayed when the induced discharge current is at a high frequency as seen during a “Stalled Rotor.” This indication should be present, for only a moment, at motor start and then disappear as rotor accelerates.

**“Fld”** - Rectifier/Exciter Field Amps signal - displayed when Field Amps exceed the minimum current threshold level giving a positive Amps signal indication.

**“PFHi”** - Synchronized Motor Power Factor signal – displayed when Motor Power Factor is better than minimum preset lagging power factor trip point, is displayed when the power factor is OK or high.

**“MFV”** - Motor Starter Full Volts Signal – displayed if Full Volts Contact “Closed” Signal is present (If Reduced Voltage Starter is NOT used the Full Volts input should have a permanent jumper installed across Input Terminals 1 and 3)

# KinetSync-SR™ by Kinetics Industries Inc.

140 Stokes Avenue  
Trenton, New Jersey 08638

## KinetSync-SR Touch Pad and LCD Display

### KinetSync-SR Touch-Pad and LCD Display Functional Description

The Touch Pad and LCD on the face of the *KinetSync-SR* has three major functions.

1. The Touch Pad is used to Acknowledge and provide a Reset function for Excitation or Control Sequence faults from the *KinetSync-SR* operating logic microprocessor after the controller alarms and shuts down the system.
2. The Touch Pad can be used to review the present settings of the *KinetSync-SR* timing functions and metering parameters.
3. With the entry of the system password, the Touch Pad can be used to modify or adjust the *KinetSync-SR* timing functions and metering parameters.

**The *KinetSync-SR* Touch-Pad is NOT functional during motor running operation.**

The optional Kinetics *KS\_PARM Windows PC* software is available for making changes to the Controller settings while the motor is "on-line" - (See page 22).

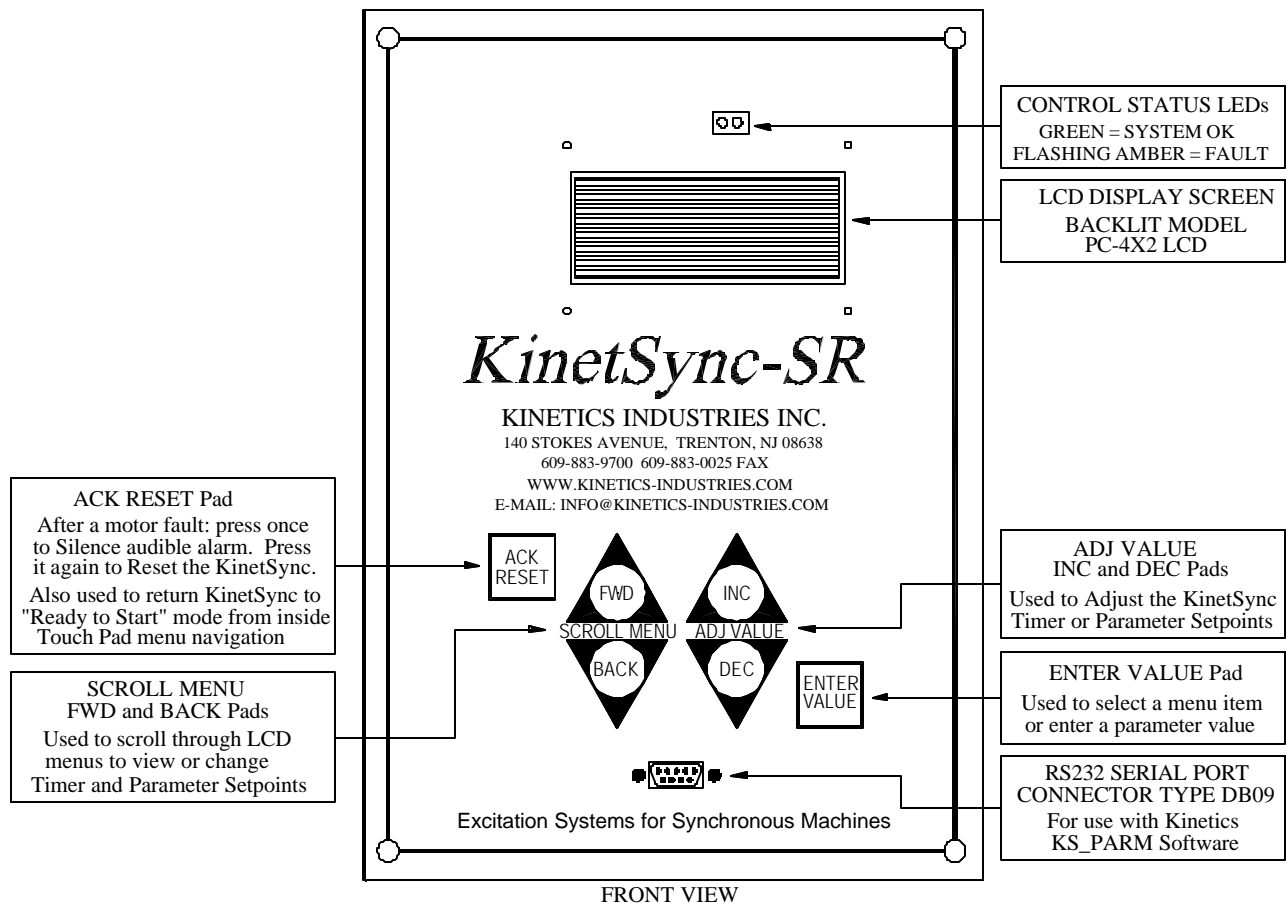

# ***KinetSync-SR™*** by *Kinetics Industries Inc.*

140 Stokes Avenue  
Trenton, New Jersey 08638

## **Fault Acknowledge and Reset Function**

When a fault occurs, the *KinetSync-SR* annunciates on its LCD screen that a “MOTOR FAULT” has occurred, identifies the fault on the LCD screen, and provides a shutdown or fault signal to the motor AC controller. It also provides a shutdown signal to the exciter power supply, sounds an audible alarm, switches the Control Status LED indicator from a steady Green to a flashing Amber LED. Finally, the *KinetSync-SR* Touch Pad is activated for Acknowledgement of the fault and System Reset.

PF	Amps	Volts
*X.XX	XX.X	XXX.X
Motor Fault		
[ FAULT ID MESSAGE ]		

With the *KinetSync-SR* in the Fault condition, pressing the Touch Pad

<ACK/RESET> turns off the audible alarm but otherwise leaves all else in the fault condition.

Touching the Touch Pad <ACK/RESET> a second time displays “HIT ENTER TO CONFIRM.” on the LCD screen. The operator should read and record the fault for future analysis.

PF	Amps	Volts
*X.XX	XX.X	XXX.X
Hit Enter to Confirm		
[ FAULT ID MESSAGE ]		

Pressing the <ENTER VALUE> Touch Pad enters a RESET signal to the microprocessor, to reset the *KinetSync-SR* and bring the controller back to the start up condition.

PF	Amps	Volts
*X.XX	XX.X	XXX.X
OK To Start		
[ DIGITAL INPUT CODES ]		



# KinetSync-SR™ by Kinetics Industries Inc.

140 Stokes Avenue  
Trenton, New Jersey 08638

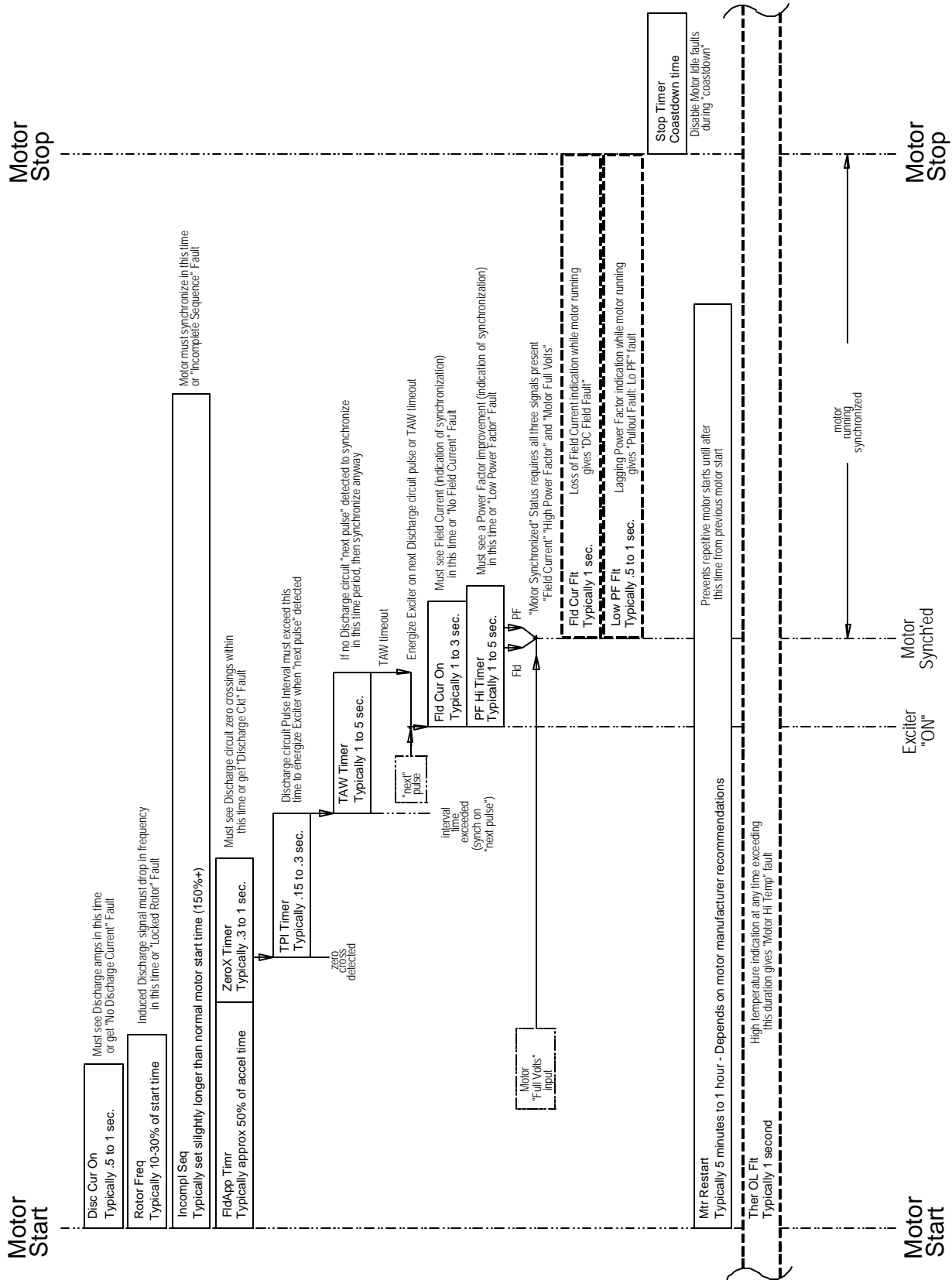

## KinetSync-SR Functional Time Line

# ***KinetSync-SR™ by Kinetics Industries Inc.***

140 Stokes Avenue  
Trenton, New Jersey 08638

## **Viewing *KinetSync-SR* Timer and Meter Settings**

The “VIEW SETTINGS” mode can be enabled when the *KinetSync-SR* is in the “OK to Start” mode as displayed on the LCD screen, the motor is not running, and power is applied to the control system.

Pressing either the <FWD> or <BACK> Scroll Menu pads on the Touch Pad will bring up the “ADJUST TIMERS” menu on the LCD screen.

```
[TIME]           [DATE]
Kinetics KinetSyncSR
Adjust Timers
```

Touching either the <FWD> or <BACK> pads again will scroll to the remaining menus, which are “ADJUST SCALING” and “ADJUST TIME/DATE”

To view timer settings, press the <ENTER VALUE> Touch Pad when the display reads “ADJUST TIMERS.” Similarly, to view metering scaling parameters, press the <ENTER VALUE> pad when the scrolling is on “ADJUST SCALING”.

When the Touch Pad <ENTER VALUE> pad is pressed with “ADJUST TIMERS” displayed, the first timer and its time setting is then displayed. (NOTE: All timer set points are in milliseconds)

```
[TIME]           [DATE]
Kinetics KinetSyncSR
Adjust Timers
[TIMER]:[SET POINT (mSec)]
```

To view the next timer, press the Touch Pad <FWD> pad again and the next timer setting will be displayed. Hitting the <BACK> pad will scroll the display back one item. Similarly, the Meter Scaling parameters can be viewed.

To EXIT “VIEW SETTINGS” Mode:

Pressing the <ACK/RESET> Touch Pad while viewing Timer or Scaling set points in “VIEW SETTINGS” mode will put the *KinetSync-SR* back into the “OK TO START” mode.

## **Adjusting the *KinetSync-SR* Timers and Meter Settings**

In order to modify the existing settings, it is required to know the *KinetSync-SR Password*. This system password is programmed into the controller using the KS\_Parm programming software. A standard password is programmed into the unit at the factory. (*This factory-programmed password is listed on the title page of this instruction book*) It can be changed using the KS\_Parm software installed on a Windows PC computer. See the manual section describing the KS\_Parm software.

To adjust timer values or meter scaling, proceed as described above in “Viewing *KinetSync-SR* Timer and Meter Settings”. Scroll through the Timers or Meter Scaling selections until the item you want to change appears on the LCD screen and then press the <ENTER VALUE> Touch Pad for the “ADJUST SETTINGS” mode.

```
12:01:01           12/31/01
Kinetics KinetSyncSR
Adjust Timers
Disc Cur On:      2000
```

A cursor will appear highlighting the right-most digit in the parameter set point. Press either the <INC> or <DEC> “Adjust Value” Touch Pads to incrementally increase or decrease the numerical value of this set point.

# KinetSync-SR™ by Kinetics Industries Inc.

140 Stokes Avenue  
Trenton, New Jersey 08638

(Note: All timer settings are shown in millisecond [.001 sec] units while meter scaling set points are in .001 increments)

The set point digit highlighted by the blinking cursor will be the one modified by pressing the <INC> or <DEC> Touch Pad.

### Example:

Press <INC> <INC> <INC>

12:01:01	12/31/01
Kinetics KinetSyncSR	
Adjust Timers	
Disc Cur On:	200 <u>3</u>

Pressing the <BACK> Touch Pad will move the cursor to the left one place.

### Example:

Press <BACK> <BACK>

Press <DEC> <DEC> <DEC> <DEC>

12:01:01	12/31/01
Kinetics KinetSyncSR	
Adjust Timers	
Disc Cur On:	1 <u>6</u> 03

Similarly, pressing the <FWD> Touch Pad will move the cursor to the right. This function allows for either coarse or fine adjustment of the parameter set point.

When the desired new set point has been achieved, press the <ENTER VALUE> Touch Pad to enter the new setting. The LCD will now prompt you to: “ENTER PASSWORD”.

12:01:01	12/31/01
Kinetics KinetSyncSR	
Enter Password:	
Disc Cur On:	1603

At this point, enter the programmed 4-Digit *KinetSync-SR Password* (A combination of the “SCROLL MENU” and “ADJ VALUE” Touch Pads) and then press the <ENTER VALUE> Pad again.

The new set point value will be entered into the *KinetSync-SR* memory and the system returns to “ADJUST SETTINGS” mode with the new set point displayed. You can now use the <FWD> or <BACK> Touch Pads to scroll another parameter to adjust. (If the new set point changes back to the original value when the <ENTER VALUE> Pad was pressed, then the wrong *KinetSync-SR Password* was entered.)

To NEGATE a changed setting before you press <ENTER VALUE> to enter the password, press the <ACK/RESET> Pad and the program will return to the “ADJUST SETTINGS” mode menu.

### To EXIT “ADJUST SETTINGS” Mode:

Pressing the <ACK/RESET> Touch Pad while in the “ADJUST TIMERS”, “ADJUST SCALING” or “ADJUST TIME/DATE” modes will put the *KinetSync-SR* back into the “VIEW SETTINGS” mode. Pressing the <ACK/RESET> once again returns the *KinetSync-SR* to the “OK TO START” mode.

## KinetSync-SR Timer Descriptions

The following is a description of the programmable timers that can be accessed via the *KinetSync-SR* LCD using the Touch Pad controls

12:01:01	12/31/01
Kinetics KinetSyncSR	
Adjust Timers	
Disc Cur On:	_____ (mSec)

### Discharge Current Timer:

Discharge circuit current must be detected within this time after motor start or else a “No Discharge Current” Fault results.

# ***KinetSync-SR™ by Kinetics Industries Inc.***

**140 Stokes Avenue  
Trenton, New Jersey 08638**

[TIME]	[DATE]
Kinetics KinetSyncSR	
Adjust Timers	
Fld Cur On: _____ (mSec)	

### **Field Current Timer:**

Field Current must be detected within this time after the *KinetSync-SR* turns on the motor exciter or else a “No Field Current” Fault results

[TIME]	[DATE]
Kinetics KinetSyncSR	
Adjust Timers	
Fld Cur Flt: _____ (mSec)	

### **Field Current Fault Timer:**

After the motor is synchronized, a loss field current cannot exceed this time duration or a “DC Field Fault” results.

[TIME]	[DATE]
Kinetics KinetSyncSR	
Adjust Timers	
Rotor Freq: _____ (mSec)	

### **Induced Rotor Frequency Timer:**

Induced rotor discharge current signal must show a drop in frequency within this time after motor start indication or else a “Locked Rotor” Fault results

[TIME]	[DATE]
Kinetics KinetSyncSR	
Adjust Timers	
PF Hi Timer _____ (mSec)	

### **Low Power Factor Timer:**

Motor power factor improvement must be detected within this time after the *KinetSync-SR* turns on the motor exciter. This improvement is a positive indication of motor synchronization and if it doesn't occur a “Low Power Factor” Fault results

[TIME]	[DATE]
Kinetics KinetSyncSR	
Adjust Timers	
Incompl Seq: _____ (mSec)	

### **Incomplete Sequence Timer:**

The motor must start up and properly synchronize within this time after a motor start or else an “Incomplete Sequence” Fault results. This timer is usually set significantly longer than the normal time required to start-up the motor.

[TIME]	[DATE]
Kinetics KinetSyncSR	
Adjust Timers	
ZeroX Timer: _____ (mSec)	

### **Zero Crossing Timer:**

This timer is started after the FldApp Timer times out. Proper Discharge circuit current indication must be detected before the ZeroX times out or a “Discharge Ckt” Fault results

[TIME]	[DATE]
Kinetics KinetSyncSR	
Adjust Timers	
Mtr Restart: _____ (mSec)	

### **Motor Restart Interlock Timer: (56K)**

This timer is started when a motor start indication is received. The *KinetSync-SR* will not allow another motor start until this timer has timed out.

[TIME]	[DATE]
Kinetics KinetSyncSR	
Adjust Timers	
Low PF Flt: _____ (mSec)	

### **PF High Timer:**

After the motor is synchronized, a low (Lagging) motor power factor indication cannot exceed this time duration or a “Pullout Fault: Lo PF” Fault results

# KinetSync-SR™ by Kinetics Industries Inc.

140 Stokes Avenue  
Trenton, New Jersey 08638

```
[TIME]      [DATE]
Kinetics KinetSyncSR
  Adjust Timers
Stop Timer:_____ (mSec)
```

### Motor Stop Timer:

After a normal Motor Shutdown this is a delay before enabling the “Before Start” Motor Field and Power Factor Faults.

```
[TIME]      [DATE]
Kinetics KinetSyncSR
  Adjust Timers
Ther OL Flt:_____ (mSec)
```

### Thermal OverLoad Timer:

A high temperature indication has been detected in the external Thermal Protection Circuit for longer than this timer duration

```
[TIME]      [DATE]
Kinetics KinetSyncSR
  Adjust Timers
FldApp Timr:_____ (mSec)
```

### FldApp Timer:

This timer is started at motor start and is a programmed-in delay before the KinetSync-SR starts to monitor the Discharge Circuit for indication of rotor speed and angle for synchronizing

```
[TIME]      [DATE]
Kinetics KinetSyncSR
  Adjust Timers
TPI Timer:_____ (mSec)
```

### Pulse Interval Timer: (TPI)

This timer monitors the time interval between Discharge Circuit signal pulses to provide an indication of when the rotor has accelerated to synchronizing speed. When the Pulse Interval exceeds this set point the motor is ready to synchronize.

```
[TIME]      [DATE]
Kinetics KinetSyncSR
  Adjust Timers
TAW Timer:_____ (mSec)
```

### Time Out Anyway Timer:

This timer is started after the motor has reached the proper synchronizing speed. If the KinetSync-SR does not detect a Discharge Circuit signal indicating rotor position before this timer times out, the Field Exciter is turned on anyway. (*This “lack of a signal” could result if a lightly loaded motor pulled into synchronization on the strength of residual rotor magnetization*)

## Adjusting Meter Display Calibration

The KinetSync-SR displays three operating Meter Parameters while running;

- Exciter DC Field Volts
- Exciter DC Field Amps
- Motor Power Factor

These three parameters are continuously updated during Run Mode and their values are displayed on the second line of the LCD screen.

```
PF      Amps      Volts
*x.XX   XX.X     XXX.X
      OK to Start
[ DIGITAL INPUT CODES ]
```

Each Meter Display has an adjustable programmed *Scaling Factor* and an *Offset* for calibration. These programmed values are adjusted by either using the front KinetSync-SR Touch Pad or the optional Kinetics KS\_Parm Windows software.

# ***KinetSync-SR™*** by *Kinetics Industries Inc.*

140 Stokes Avenue  
Trenton, New Jersey 08638

## **Exciter Volts and Amps Calibration**

*The Volts and Amps signals are provided to the controller from Hall Effect transducers on the Rectifier/Exciter output. For 125VDC brush-type exciters the Hall Effect transducer ratios are normally:*

150VDC → 4 VDC input to the  
*KinetSync-SR* A/D converter

100 ADC → 4 VDC input to the  
*KinetSync-SR* A/D converter

To adjust the Metering Calibration of the *KinetSync-SR* Display you must enter the “ADJUST SCALING” mode. This mode can be accessed when the *KinetSync-SR* is in the “OK to Start” mode on the LCD screen, while the motor is not running, and power is applied to the control system.

Pressing either the <FWD> or <BACK> Scroll Menu pads on the Touch Pad will bring up the “ADJUST TIMERS” menu on the LCD screen. Pressing the <FWD> or <BACK> Pads at this point will scroll to the additional “ADJUST SCALING” and “ADJUST TIME/DATE” screens.

To enter the “VIEW SCALING” mode, press the <ENTER VALUE> Touch Pad when the display reads “ADJUST SCALING.”

[TIME]	[DATE]
Kinetics KinetSyncSR	
Adjust Scaling	
[PARAMETER]:	[SET POINT]

Pressing the <FWD> or <BACK> Touch Pads will now scroll through the different meter calibration parameters for the *KinetSync-SR* LCD Display. When the Meter Parameter you wish to modify is displayed, press the <ENTER VALUE>

Touch Pad again to enter the “ADJUST SCALING” mode.

A cursor will appear highlighting the right-most digit in the Parameter set point.

12:01:01	12/31/01
Kinetics KinetSyncSR	
Adjust Scaling	
DC Volts SF:	105 <u>0</u>

Press either the <INC> or <DEC> “Adjust Value” Touch Pads to incrementally increase or decrease the numerical value of this highlighted digit or move the cursor right or left using the <FWD> and <BACK> pads to affect either a coarse or fine numerical adjustment.

12:01:01	12/31/01
Kinetics KinetSyncSR	
Adjust Scaling	
DC Volts SF:	11 <u>50</u>

Finish by pushing the <ENTER VALUE> Touch Pad and you will be prompted to enter the Password as described in the “Adjust Timers” section of this manual.

12:01:01	12/31/01
Kinetics KinetSyncSR	
Enter Password:	
DC Volts SF:	1150

## **Scaling Factors and Offset**

The Scaling Factor for each of the *KinetSync-SR* input parameters is based on a 10VDC max input providing a screen annunciation of the entered scaling factor. (A Scaling Factor of 500 with 10VDC Field Volts signal input yields 500VDC on the LCD screen for exciter Volts).

# ***KinetSync-SR™ by Kinetics Industries Inc.***

**140 Stokes Avenue  
Trenton, New Jersey 08638**

If the Volts Transducer ratio is 150V = 4V  
then the calculated scale factor is:

$$10 * 150 / 4 = \underline{375}$$

Thus, a 10V input signal yields 375 VDC

**And:**

A 4V input signal will display 150 VDC.

If the Field Current Transducer ratio is  
100A = 4V then the calculated scale factor  
would be:

$$10 * 100 / 4 = \underline{250}$$

Thus, 10V would give 250 ADC

**And**

A 4V input will display 100 ADC

The Volts and Amps Display parameters each include an Offset (Zero) adjustment to compensate for any analog amplifier interface variations. This Offset is the programmed value, which will yield a Zero output on the LCD when the Input signal (Field Volts or Amps) to the *KinetSync-SR* is shorted. This offset value is typically in the range of 90 to 110 for both Volts and Amps.

## **Power Factor Scaling Factors**

Unlike the Volts and Amps displays, the Power Factor value is dual polarity to reflect that this parameter can be either Leading (positive) or Lagging (negative). The *KinetSync-SR* internal Power Factor Circuit generates a voltage signal which corresponds to motor power factors from zero power factor “Lagging” to zero power factor “Leading.” Like the Field Amps and Field Volts inputs, the Power Factor display has Scaling Factor and Offset adjustments to compensate for analog amplifier interface variations.

This offset is the numerical value that will display a 1.0 on the LCD when the internal Power Factor Circuit signal output to the *KinetSync-SR A/D converter* is shorted to provide an absolute zero or null signal. This Power Factor Offset value is normally in the range of 1900 to 2100 for the Power Factor display.

The *KinetSync-SR* internal Power Factor Circuit Amplifier output signal ranges from -3 VDC at 0.00 Lag power factor to +3 VDC at 0.00 Lead power factor. This signal has a sine wave profile based on the sine of the motor power factor angle. The *KinetSync-SR* processor converts this input signal to the equivalent power factor value (i.e. cosine of power factor angle) that it then displays on the LCD. The scaling factor is based on 5 volts full scale input. The algorithm used is:

$$(P.F.out) * (P.F.s.f.) / 5 = \text{SINE}(P.F.\text{angle})$$
$$P.F. \text{ Display} = \text{COS}(\text{arcsine}(P.F.\text{angle}))$$

Where:

P.F.out = Power Factor Circuit output  
P.F.s.f. = Power Factor Scaling Factor  
P.F.angle = Motor Power Factor Angle  
P.F. Display = LCD Power Factor value

**Note:** *The Power Factor Scaling Factor and Offset can vary over a wider range than that of the Volts or Amps parameters as the 5 volts input is only a nominal value.*

The above calculation provides a ballpark adjustment level but the best calibration is provided by scaling to the values shown below:

**Internal P.F. Circuit calibration:**

-2.4 VDC → -.6 pf  
-1.8 VDC → -.8 pf  
\*0.0 VDC → 1.0 pf  
+1.8 VDC → +.8 pf  
+2.4 VDC → +.6 pf

# ***KinetSync-SR™*** by *Kinetics Industries Inc.*

140 Stokes Avenue  
Trenton, New Jersey 08638

## **KinetSync-SR Metering Parameters**

The following is a list of the programmable Metering Calibration parameters that can be accessed via the *KinetSync-SR* LCD using the Touch Pad controls.

```
12:01:01      12/31/01
Kinetics KinetSyncSR
Adjust Scaling
DC Volts SF: _____
```

### **DC Field Volts Scaling Factor**

```
12:01:01      12/31/01
Kinetics KinetSyncSR
Adjust Scaling
DC VltS Off: _____
```

### **DC Volts Offset**

```
12:01:01      12/31/01
Kinetics KinetSyncSR
Adjust Scaling
DC Amps SF: _____
```

### **DC Field Amps Scaling Factor**

```
12:01:01      12/31/01
Kinetics KinetSyncSR
Adjust Scaling
DC Amps OFF: _____
```

### **DC Field Amps Offset**

```
12:01:01      12/31/01
Kinetics KinetSyncSR
Adjust Scaling
Pwr Fac SF: _____
```

### **Power Factor Circuit Scaling Factor**

```
12:01:01      12/31/01
Kinetics KinetSyncSR
Adjust Scaling
Pwr Fac SF: _____
```

### **Power Factor Circuit Offset**

## **KS\_Parm Program Description**

The KS\_Parm program is available from Kinetics Industries, as a *KinetSync-SR* accessory, to aid the user in obtaining optimum usage from this controller.

The same Touch Pad parameter viewing and modification functions described above are available using the KS\_Parm program on a Windows PC computer connected via a serial connection to the RS232 serial port on the front of the *KinetSync-SR*.

## **Additional Functions of the KS\_Parm program include:**

- Changing or setting the access password for the *KinetSync-SR*
- Modifying the time and date settings for the *KinetSync-SR* fault review table
- Reviewing the fault history of the *KinetSync-SR*
- Ability to review and change settings while the *KinetSync-SR* is in operating mode (while the motor is running)



# *KinetSync-SR™ by Kinetics Industries Inc.*

140 Stokes Avenue  
Trenton, New Jersey 08638

## Trouble Shooting Guide for *KinetSync-SR*Ô

<b>LCD Alarm Message:</b>	<b>Possible Cause:</b>	<b>Action Required:</b>
<b>DC On Before Start</b>  <i>KinetSync-SR detects field current without the motor running</i>	<b>1. Rectifier “Test/Run” Switch in “Test” position and SVR Rectifier Exciter has a DC output</b>  <b>2. Incorrect FS Relay connection</b>	- Move “Test/Run” switch to “Run” position and reset controller.  - Check FS Relay wiring at <i>KinetSync-SR</i> Output Terminal strip connection (points 10 and 11) and at SVR Rectifier Input Terminal strip - Check that the <i>KinetSync-SR</i> Output Terminal strip is properly seated in terminal strip receptacle
<b>Low PF Before Start</b>	<b>Motor Running w/o field before <i>KinetSync-SR</i> receives Start indication</b>	- Check why motor running before start indication - Check Motor “Start” (#52) contact circuit to <i>KinetSync-SR</i> Input Terminal strip (points 1 and 2) - Check that the <i>KinetSync-SR</i> Input Terminal strip is properly seated in terminal strip receptacle
<b>No Discharge Current</b>  <i>KinetSync-SR fails to detect Discharge Circuit current after receiving a motor start indication</i>	<b>1. Open or incorrect discharge circuit connection</b>  <b>2. Incorrect Discharge Circuit Transducer cable connection</b>  <b>3. Incorrect DST Relay connection</b>  <b>4. Insufficient Discharge Current to exceed min threshold level</b>	- Check that Discharge resistor is properly connected to SVR Rectifier  - Check that the Kinetics Discharge Transducer Cable is properly plugged in to “DISC AMPS” location on back of <i>KinetSync-SR</i> case and at the SVR Discharge Amps Hall Effect Transducer  - Check DST Relay wiring at <i>KinetSync-SR</i> Output Terminal strip connection (points 7 and 8) and at SVR Rectifier Input Terminal strip  - Disconnect Discharge Resistor lead cable from SVR (10D) and add a loop through the Discharge Current Hall Sensor Transducer before reconnecting in original location (10D) - (2 turns vs. 1 doubles the signal strength)
<b>Locked Rotor Fault</b>  <i>KinetSync-SR detects signals characteristic of a Locked Rotor Fault</i>	<b>Motor rotor stalled or not accelerating properly during motor start.</b>  <b>Locked Rotor Amps drop off timer set point is too short</b>	- Check the condition of motor load bearings and/or other conditions that would affect the free turning of the motor rotor  - Increase Rotor Freq Timer set point slightly
<b>Discharge Ckt Fault</b>  <i>KinetSync-SR fails to detect signals used to indicate the proper rotor frequency and position</i>	<b>1. Incorrect Discharge Circuit Transducer cable connection</b>  <b>2. <i>KinetSync-SR</i> not detecting proper Discharge circuit signal</b>	- Check that the Kinetics Discharge Transducer Cable is properly plugged in to “DISC AMPS” location on back of <i>KinetSync-SR</i> case and at the SVR Discharge Amps Hall Effect Transducer  - Disconnect Discharge Resistor lead cable from SVR (10D) and add a loop through the Discharge Current Hall Sensor Transducer before reconnecting in original location (10D)

# KinetSync-SR™ by Kinetics Industries Inc.

140 Stokes Avenue  
Trenton, New Jersey 08638

<p><b>No Field Current</b></p> <p><i>KinetSync-SR fails to detect Exciter current after sending a "turn-on" signal to Exciter</i></p>	<ol style="list-style-type: none"> <li>1. SVR rectifier output not adjusted properly.</li> <li>2. Incorrect Field Circuit Transducer cable connection on back of <i>KinetSync-SR</i></li> <li>3. Incorrect FS Relay connection</li> <li>4. No Rectifier Output</li> <li>5. No Field Current, open Field circuit at SVR output, motor field, brushes, or leads</li> </ol>	<ul style="list-style-type: none"> <li>- Place "TEST/RUN" switch in "TEST" position and adjust the SVR Output Adjust Pot to get rated field amps from rectifier. Return switch to "RUN" position and RESET <i>KinetSync-SR</i> Controller</li> <li>- Check that the Kinetics Field Current Transducer Cable is properly plugged in to "FIELD AMPS" location on back of <i>KinetSync-SR</i> case and at the SVR Field Amps Hall Effect Transducer</li> <li>- Check FS Relay wiring at <i>KinetSync-SR</i> Output Terminal strip connections (points 10 and 11) and at SVR Rectifier Input Terminal strip.</li> <li>- Check the <i>KinetSync-SR</i> Output Terminal strip is properly seated in terminal strip receptacle</li> <li>- Troubleshoot SVR rectifier to get proper output voltage and current</li> <li>- Check and correct motor field circuit wiring.</li> <li>- Confirm motor field leads properly connected to SVR rectifier output</li> </ul>
<p><b>Low Power Factor</b></p> <p><i>KinetSync-SR fails to detect improvement in motor power factor after sending a "turn-on" signal to Exciter</i></p> <p><i>* The KinetSync-SR LCD should display a negative (LAG) power factor value during motor starts (prior to motor synchronization) This PF value should increase in a positive direction upon synchronization. After synchronization, the motor power factor can be adjusted Leading (positive) by increasing field excitation and Lagging (negative) by decreasing excitation</i></p> <p><i>A positive (LEADING) power factor prior to synchronizing indicates</i></p>	<ol style="list-style-type: none"> <li>1. SVR rectifier (Exciter) output set too low</li> <li>2. Discharge Resistor is still connected in parallel with Motor Field thereby decreasing excitation amps reaching the field windings</li> <li>3. Motor shaft load too great for motor to pull in to synchronization</li> <li>4. Incorrect motor starter voltage and current signal connections. (PT and CT signals not connected correctly or to correct phase at the Motor Starter, SVR Input, or <i>KinetSync-SR</i> Input)</li> </ol>	<ul style="list-style-type: none"> <li>- Check and/or adjust SVR rectifier output as described above in "No Field Current" Fault (#1)</li> <li>- Check for Discharge Resistor voltage after motor synchronization (SK11 &amp; SK12 still conducting)</li> <li>- Check FWT and DST Relay wiring at <i>KinetSync-SR</i> Output Terminal strip connection (points 5-6 and 7-8) and at SVR Rectifier Input Terminal strip for proper connection (not reversed)</li> <li>- Reduce motor loading during starts or unload motor until after synchronization</li> <li>- Check the condition of motor load bearings and/or other conditions that would affect the free turning of the motor rotor</li> <li>- Check that the motor PT and CT signals are connected to correct phases (normally PT = phase A and B; CT = phase C.)</li> <li>- Check that the motor PT/CT wiring is correct to the SVR rectifier Input Terminal strip PT and CT connection points and connected properly</li> <li>- Check the <i>KinetSync-SR</i> Input Terminal strip PF Volts and PF Amps connections (points 11-12 and 15-16) are connected properly</li> <li>- Check the <i>KinetSync-SR</i> Input Terminal strip is properly seated in terminal strip receptacle</li> <li>- Check that PT fuses are OK and disconnects are closed</li> </ul>

# KinetSync-SR™ by Kinetics Industries Inc.

140 Stokes Avenue  
Trenton, New Jersey 08638

<p>synchronizing indicates incorrect PT and CT phasing that must be corrected.</p>		<p>* If the motor starter PT and CT phase connections are confirmed correct as described above and the LCD power factor is discovered to be opposite of that expected, (see description at left) then reverse the wires at the KinetSync PF Amps input on the Input Terminal strip (points 15-16) * This procedure should only have to be performed during system commissioning</p>
<p><b>DC Field Fault</b></p> <p><i>KinetSync-SR detects loss of Excitation while synchronized</i></p> <p>--</p> <p>* Fault occurs only when PF Regulation Switch is closed (Enabled)</p>	<p>Loss of Excitation while motor is running</p> <p>--</p> <p>* Power Factor regulation signal polarity is incorrect</p>	<p>- Check FS Relay wiring at <i>KinetSync-SR</i> Output Terminal strip (points 10 and 11) and SVR Rectifier Input Terminal strip for loose connections. Also, Check that Output Terminal strip is properly seated in terminal strip receptacle</p> <p>--</p> <p>- Check that the <i>KinetSync-SR</i> Displayed Power Factor varies as described above in “Low Power Factor” fault section (correct if necessary)</p> <p>- Check PF Regulator Signal wiring connections between <i>KinetSync-SR</i> output and SVR Input Terminal Strip (see electrical schematic drawings)</p>
<p><b>Pullout Fault: Lo PF</b></p> <p>* Fault occurs during normal motor running</p> <p><i>KinetSync-SR detects low (Lagging) power factor while synchronized that indicates improper motor operation or excitation</i></p> <p>--</p> <p>* Fault occurs only when PF Regulation Switch is closed (Enabled)</p>	<p>1. Motor has pulled out of synchronization due to excessive overload</p> <p>2. SVR rectifier (Exciter) output set too low</p> <p>3. Motor Field circuit problem (see No Field Current) above</p> <p>--</p> <p>4. Incorrect motor starter voltage and current signal connections. (PT and CT signals not connected correctly or to correct phase at the Motor Starter, SVR Input, or <i>KinetSync-SR</i> Input)</p> <p>5. Power Factor regulation signal polarity is incorrect</p>	<p>- Check the condition of motor load bearings and/or other conditions that would affect motor loading</p> <p>- Adjust SVR rectifier output as described above in “No Field Current” Fault (#1)</p> <p>- See “No Field Current Fault” above for checks and remedies</p> <p>--</p> <p>- See “Low Power Factor Fault” above for checks and remedies</p> <p>--</p> <p>- With PF Regulation Switch open (Disabled), Check that the <i>KinetSync-SR</i> Displayed Power Factor varies as described above in “Low Power Factor” fault section (correct if necessary).</p> <p>- If <i>KinetSync</i> Power Factor Display varies correctly, check PF Regulator Signal wiring connections between <i>KinetSync-SR</i> output and SVR Input Terminal Strip (see electrical schematic drawings)</p>

# *KinetSync-SR™ by Kinetics Industries Inc.*

140 Stokes Avenue  
Trenton, New Jersey 08638

<p>Motor Hi Temp</p> <p>--</p> <p><i>* Alarms Immediately upon energizing KinetSync-SR</i></p> <p>--</p> <p><i>* Alarms occur while the system/motor is running</i></p>	<p>1. SVR Regulated Exciter Over-temperature</p> <p>--</p> <p>2. Broken signal continuity in External Thermal Protection circuit</p> <p>--</p> <p>3. SVR Exciter operating above rated output and/or ambient temperature</p> <p>4. Bridge semiconductor or fuse open (unbalanced bridge current)</p>	<p>If no thermal protection devices are being used, install a jumper on the Thermal Circuit input to the KinetSync Input Terminal strip (points 1 and 4)</p> <p>--</p> <p>- Check the Thermal Protection circuit connections at the <i>KinetSync-SR</i> Input Terminal strip (points 1 and 4) and at the SVR Input Terminal strip for continuity.</p> <p>- Check that KinetSync-SR Input Terminal strip is properly seated in terminal strip receptacle</p> <p>--</p> <p>- Do not exceed SVR nameplate ratings</p> <p>- Check for blocked airflow inputs or outputs on SVR enclosure</p> <p>- Check SVR Bridge for blown power fuses</p>
<p>Incomplete Sequence (Accompanied by additional concurrent alarm)</p> <p><i>KinetSync-SR detects improper / incomplete start sequence</i></p> <p>--</p> <p>Incomplete Sequence Alarm alone (No concurrent faults) -- No "MFV" digital input code on LCD during motor start</p>	<p>See concurrent faults' identification</p> <p>--</p> <p>Starter Motor Full Volts contact / connections:</p> <p><i>Motor "Full Volts" contact should close when a reduced-voltage-start motor switches to full armature volts</i></p>	<p>- See procedures for identified concurrent faults</p> <p>--</p> <p>- Check that the KinetSync-SR Input Terminal strip is properly seated in terminal strip receptacle</p> <p>- Check Motor "Full Volts" starter contacts and connections to <i>KinetSync-SR</i> Input Terminal strip (points 1 and 3)</p> <p><i>When reduced voltage starting / "Full Volts" contact is not used, install a permanent jumper on the KinetSync-SR Input Terminal strip (between points 1 and 3)</i></p>

## Additional KinetSync-SR Troubleshooting Notes

The following is an additional list of possible problems which might occur during installation, startup, or during operation due to external circumstances.

1. The *KinetSync-SR* LCD screen is not illuminated and there is no readout  
Possible cause: 120vac control power may not be reaching *KinetSync-SR* controller

Action: Check *KinetSync* Input Terminal strip connections (points 9-10) for 120vac control voltage  
Check that Input Terminal strip is properly seated in terminal strip receptacle  
Check that the Input Fuse on back of *KinetSync-SR* is good and is properly seated in place.  
(Input Fuse is tan rectangular piece protruding through upper center of back cover)

# ***KinetSync-SR™ by Kinetics Industries Inc.***

**140 Stokes Avenue  
Trenton, New Jersey 08638**

**2. No DC Amps or DC Volts display on LCD when Exciter is on (“Test/Run” Switch in “Test”)**  
Possible cause: SVR Rectifier has no output

Field Volts or Amps Hall Effect Transducer signal connection is not effective

**Action:** Troubleshoot SVR Rectifier for “No Output” fault

Check that Field Volts and Current Transducer Cables are installed properly and connecting plugs are properly seated at *KinetSync-SR* and at Hall Effect Transducers.

**3. No *KinetSync-SR* controller action when motor starts**

Possible Cause: Incorrect Motor Start contacts connection to Input terminals strip 1 and 2

**Action:** Check *KinetSync-SR* Input Terminal strip connections (points 1 and 2) (Motor Start Input)

Check *KinetSync-SR* Input Terminal strip is properly seated in terminal strip receptacle

Check Motor Start contacts of Motor Starter and associated wiring to *KinetSync-SR*

**4. Motor can still be started even when *KinetSync-SR* LCD displays “Restart Delay Lock”**

Possible cause: 56K Relay contacts are not connected properly in Motor Start / Stop circuit

**Action:** Check *KinetSync-SR* Output Terminal strip is properly seated in terminal strip receptacle

Check *KinetSync-SR* Output Terminal strip connections (points 1 and 2) (56K N.O. contact)

Check that 56K Relay output function is wired in series with Motor “Start / Stop” circuit

**5. Motor won’t start even though *KinetSync-SR* LCD displays “OK to Start”**

Possible causes: 56K Relay contacts are not connected properly in Motor “Start / Stop” circuit

FAL Relay contacts are not connected properly into Motor “Start / Stop” circuit

**Action:** Check *KinetSync-SR* Output Terminal strip is properly seated in terminal strip receptacle

Check *KinetSync-SR* Output Terminal strip connections (points 1 and 2) (56K N.O. contact)

Check that 56K Relay output function is wired in series

Check *KinetSync-SR* Output Terminal strip connections (points 12-13) (FAL N.O. contact)

Check that FAL Relay output function is wired in series with Motor “Start / Stop” circuit or in parallel with Breaker Trip circuit (if used).

*\* The FAL relay is a fail-safe (fails de-energized) relay. FAL N.O. contacts (Output points 12-13) are used with electrically held starters while FAL N.C. contacts (Output points 13-14) are to be used with mechanically held circuit breakers using tripping coils.*

**6. With motor running, placing the Power Factor Control Switch in “Enable” mode reduces field current abruptly and *KinetSync-SR* trips motor on either “No DC Field Amps” or “Low Power Factor” Fault**

Possible cause: Polarity of power factor signal from *KinetSync-SR* to rectifier regulator is incorrect

Motor Starter PT and CT signals not connected correctly or to correct phase at the Motor Starter, SVR Input, or *KinetSync-SR* Input)

**Action:** With motor running in Power Factor “Disabled” mode, vary Field Exciter Current with

operator’s output adjust pot: as current decreases, the Power Factor display should go less leading (less +) or more lagging (more -). At unity power factor (1.0), the motor armature current should be at some minimum level that increases as you vary the Motor Power Factor in either a leading or a lagging direction. If the *KinetSync-SR* Power Factor display and motor armature current react in this manner, the signal polarity is OK and the output from *KinetSync* Power Factor terminal strip (points 3 and 4)

# ***KinetSync-SR™ by Kinetics Industries Inc.***

**140 Stokes Avenue  
Trenton, New Jersey 08638**

may be reversed. If the *KinetSync-SR* Power Factor display does not react as described above, there is a possible polarity or phase problem with the CT and PT connections from the starter. (see below)

*The KinetSync-SR requires that the CT and PT signals be in quadrature*

**Possible correct combinations:**

<b>CT phase C</b>	<b>PT phase A-B</b>	<b>** Standard connection configuration</b>
<b>CT phase A</b>	<b>PT phase B-C</b>	
<b>CT phase B</b>	<b>PT phase C-A</b>	<b>*** Undesired connection for open-delta PT configurations</b>

If the PT and CT configuration is correct (as shown above), and the *KinetSync-SR* power factor display varies opposite than described, then reverse the PF Amps input wires at the *KinetSync-SR* Input Terminal strip (points 15-16). Confirm proper Power Factor Display behavior by running motor and varying Field Exciter Current as described above. \* This procedure should only have to be performed once during system commissioning and the connections left unchanged thereafter.

***KinetSync-SR™ by Kinetics Industries Inc.***

**140 Stokes Avenue**

**Trenton, New Jersey 08638**

## **How to Get Assistance**

**For technical or application assistance**

**Email: [Info@Kinetics-Industries.com](mailto:Info@Kinetics-Industries.com)**

**Fax: Engineering Assistance at Kinetics Industries, Inc.  
1-609-883-0025**

**Phone: 1-609-883-9700  
Normal business hours are 8:00AM to 4:30PM EST**

**Mailing and/shipping address:**

**Kinetics Industries, Inc.  
140 Stokes Avenue  
Trenton, N.J. 08638**

**When contacting for any reason concerning a particular system, the following information concerning the system is necessary:**

**System Model Number, System Number, and Nameplate Data**

**Customer/Purchaser Name and Address**

**Date of purchase and Date of commissioning**

**If an operational problem:**

**A list of the last fault readouts and annunciation**

**A description of the problem and/or symptoms.**

***KinetSync-SR<sup>TM</sup> by Kinetics Industries Inc.***  
**140 Stokes Avenue**  
**Trenton, New Jersey 08638**

Notes:



***KinetSync-SR™ by Kinetics Industries Inc.***

**140 Stokes Avenue  
Trenton, New Jersey 08638**

**STANDARD STATEMENT OF WARRANTY AND  
LIMITATION OF LIABILITY**

Equipment manufactured by Kinetics Industries, Inc., is guaranteed for a period of one year from date of shipment against defects in materials and/or workmanship and to operate in accordance with our proposals, specifications and nameplate data under conditions of proper installation, rated load, environment and usage. Any defects in materials and/or workmanship will be repaired or replaced at our option, F.O.B. our plant or, at our option, in the field under straight time conditions. Kinetics shall in no event be responsible for special, indirect, or consequential damages, nor for repairs or replacements made by others without written authorization of Kinetics. Correction of defects by repairing or replacing shall constitute the fulfillment of Kinetics warranty.

Kinetics' liability on any claim of any kind, including negligence, for any loss or damage arising out of, connected with, or resulting from the sale of Kinetics' equipment shall in no case exceed the total price paid to Kinetics for such equipment.

The foregoing warranty is in lieu of any other warranty or obligation, expressed or implied, and no liability is assumed by Kinetics Industries, Inc. except as is expressly stated above.

It is expressly understood and agreed that Kinetics makes no warranty with respect to any equipment not manufactured by Kinetics or with respect to any components of Kinetics' equipment manufactured by others. In all such cases, the Buyer shall rely solely on the warranty of the manufacturers of such equipment or component, if any.

This document is based on information available at the time of its publication. While efforts have been made to ensure accuracy, the information contained herein does not cover all details or variations in components and programming, nor does it provide for every possible contingency in connection with installation, operation and maintenance. Features may be described herein that are not present in all physical components and logical sequence configuration. Kinetics Industries, Inc. makes no representation or warranty, expressed, implied, or statutory, with respect to, and assumes no responsibility for the accuracy, completeness, sufficiency, or usefulness of the information contained herein.